

**INSTRUCTION**

***CM-P* SERIES**

**Industrial Sewing Machines**

**使用説明書**  
**INSTRUCTION**

# 说明

---

感谢您购买 *CM-P* 系列特种缝纫机：

请在使用前务必仔细阅读并了解本使用指导说明书。请将说明书保存好以备。

# 目录

# ***CONTENTS***

## 1、规格说明

1-1线迹.....	1
1-2型号.....	1

## 2、针/穿线

2-1 穿线

## 1、SPECIFICATIONS

1-1 Stitch type.....	1
1-2 Model.....	1

## 2、NEEDLES & THREADING THE MACHINE

2-1 Needles

This page is almost entirely obscured by heavy black redaction bars, rendering the content unreadable. Only a few faint characters are visible in the left margin, including "41" and "11".

## 2-3 穿线的方法

请参照下一页正确穿线

不正确的穿线会导致跳针/断线甚至错误的线迹。穿线的时候,向机器的前方倾斜弯针架。

### 2-3 TO THREAD THE MACHINE

Thread the machine correctly by referring to the next page. Incorrect threading may cause skip stitching, thread breakage and/or uneven stitch formation.

~~When threading the looper, tilt the looper holder toward the front of the machine by means of the looper~~

#### ■ 如何倾斜弯针架到前方

1. 将针杆升到最高点时;
2. 对于1507和1508,用手按下弹性按钮A(如下图所示)使弯针架B倾斜到前方;
3. 对于1501到1504,按右边的连杆C倾斜弯针架D;
4. 穿好线后将弯针架复原。

#### TO TILT THE LOOPER TOEARD THE FRONT

1. Bring the needle bar to the top of its stroke.
2. On 1507 and 1058, tilt looper holder B toward the front of the machine by pressing pushbutton

■A, B, C, D...机针线

E, F, G, H...弯针线

■A, B, C, D... Needle threads

E, F, G, H... Loper threads

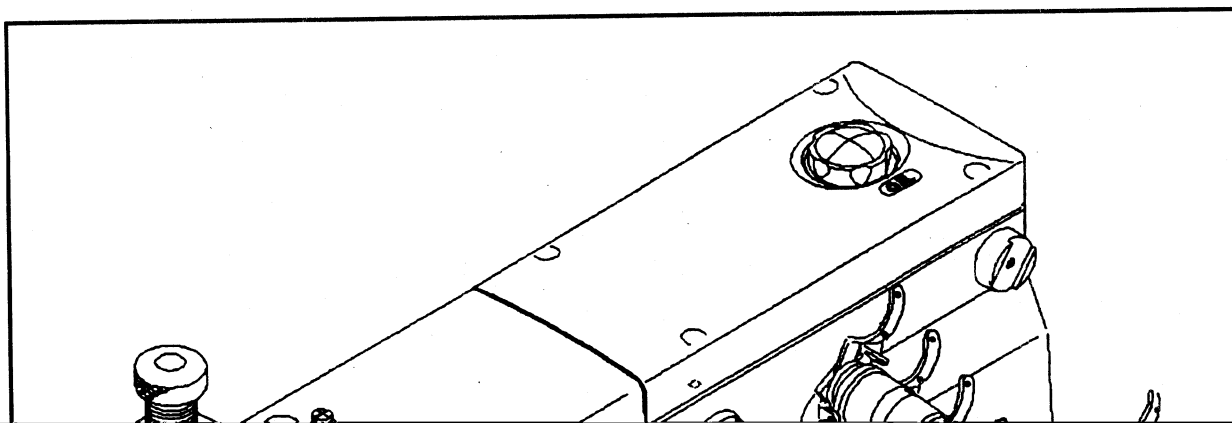

### 【3】缝 纫 速 度 — MACHINE SPEED

#### 3-1 缝制速度与皮带轮的运转方向

最大速度：4500转/分

标准速度：4000转/分

在使用新缝纫机时，最初的200个小时(大约1个月)采用最高缝纫速度的15-20%左右的低速运转后，再采用常用缝纫速度，可延长机器使用

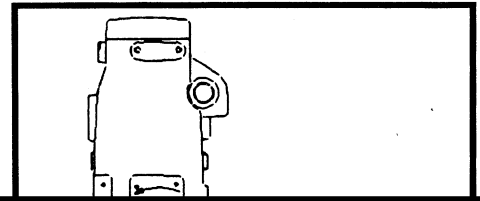

#### 4-1 使用的机油

请使用本公司SPECIAL纯正机油(品名28-611)。

#### 4-1 OIL

Use Special,s genuine oil. (Part No.28.611)

#### 4-2 添加润滑油

取下注油口的油镜盖A, 向注油口灌注油直到油标C的上线(图示H)为止。平常补充油时, 请保持油面在H和L之间, 注油结束后, 运转缝纫机, 确认机油有否喷到油面窗A处。

#### 4-2 TO FILL THE MACHINE WITH OIL

Remove oil plug A

Fill the machine with oil until the oil level is at the top line (see H in the illustration) on oil gauge C. After the first lubrication, add oil so that the oil level will between H and L. After filling the machine the oil, tighten plug A and run the machine to check the oil is splashing onto oil pot A.

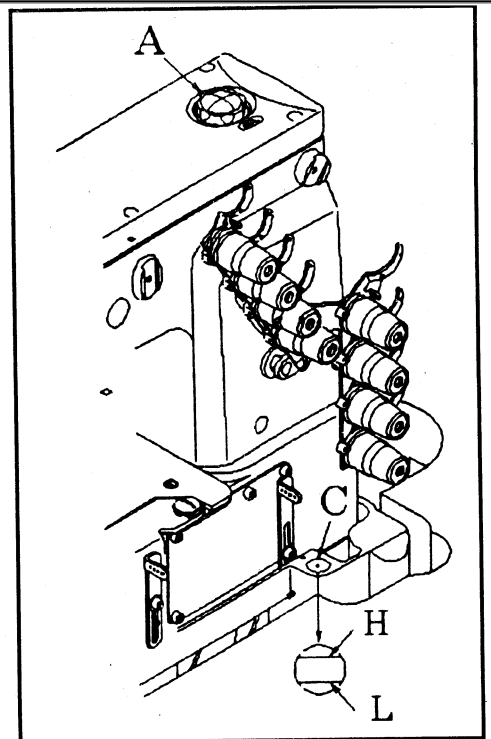

#### 4-3 机油、油泵滤网的清扫

为了延长和保证缝纫机的使用寿命, 在新缝纫机使用250小时左右后, 必须全部更换机油, 在更换机油时。

请按照以下步骤进行:

- 1、把V形皮带从电机皮带轮上卸下来, 然后从缝纫机台上拆下缝纫机。
- 2、取下排油螺钉D、排出机油, 这时确认V形皮带没有粘到机油。
- 3、排放完机油后, 必须把螺钉D拧紧。
- 4、按照前项4-2的步骤, 给缝纫机注油。

#### 4-3 REPLACING THE OIL AND THE FILTER ELEMENT

To extend machine life ,be sure to replace the oil after the first 250 hours of operation.

To replace the oil, follow the procedures below:

- 1.Remove the V belt from the motor pulley and then remove the machine from the table;
- 2.Remove screw D and then drain the oil;  
Be careful not to stain V belt with the oil.
- 3.After draining the oil, be sure to tighten screw D;

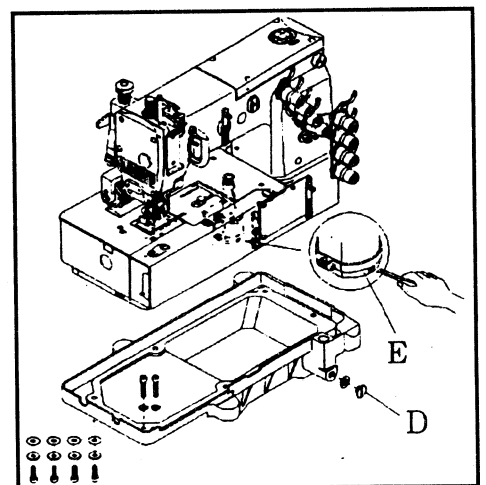



**[5] 缝纫机的安装—SEWING MACHINE INSTALLATION**

**5-1 台板分解图**

**5-1 CUTTING THE MACHINE TABLE**

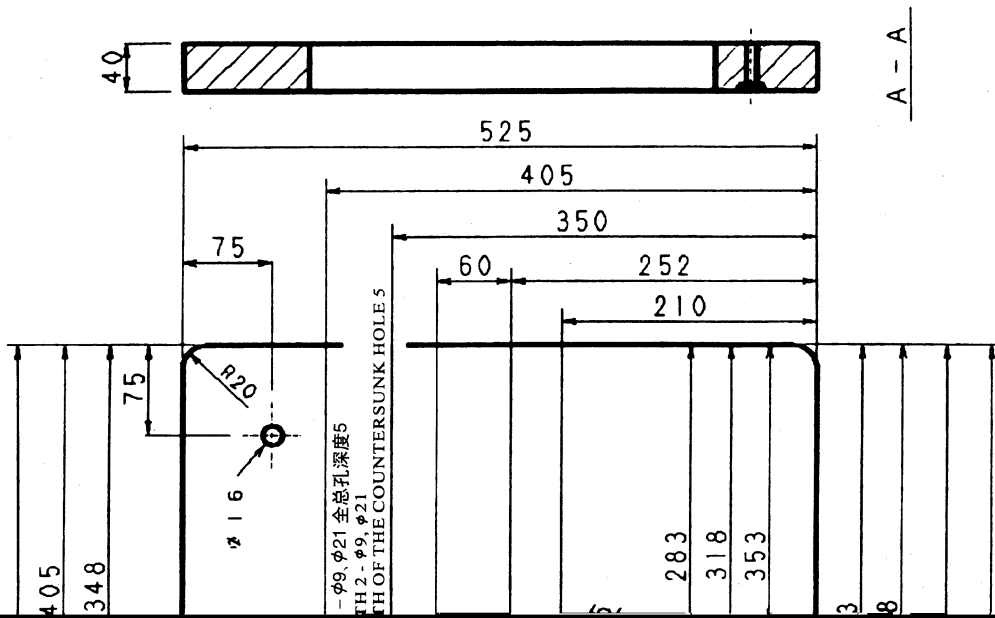

## 5-2 缝纫机的安装

参考图示，把支撑架安装在缝纫机工作台上，然后把缝纫机平稳地安放在橡胶垫上。

### 5-2 TO INSTALL THE MACHINE

Install the brackets on the underside of table board (see the illustration below).

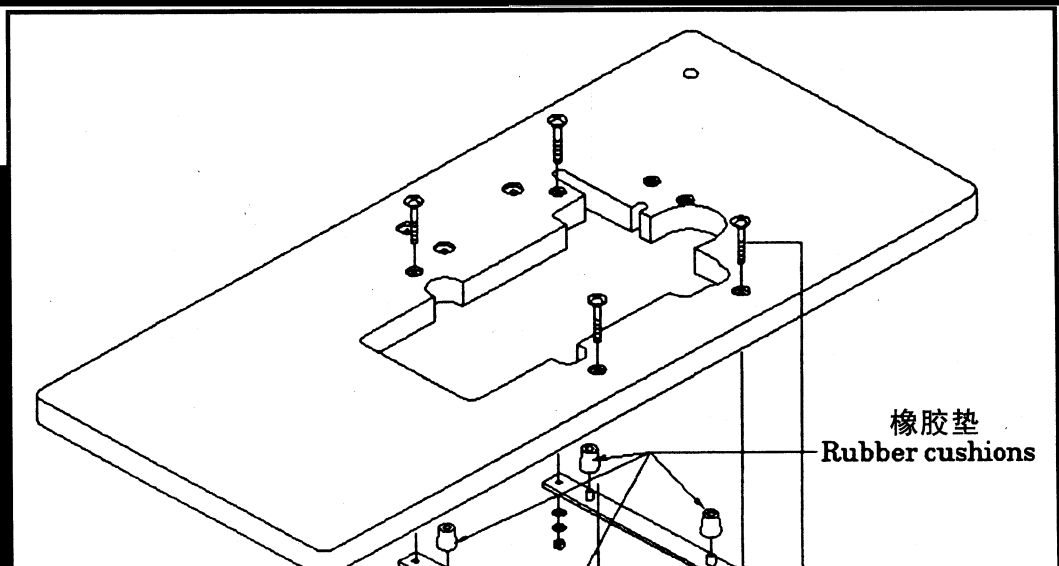

## 6-2 弯针往返运动的同步调节



## 6-4 机针高度调节

针杆的高度以缝纫机运转方向上，弯针尖穿过左针的左端时，从针背的线孔的上端到弯针尖的尺寸2mm表示(如图6-2)。调节的方法是，当针杆最高时，取下调整套A，拧松针杆尖B上定位螺钉C，然后上下调节针杆

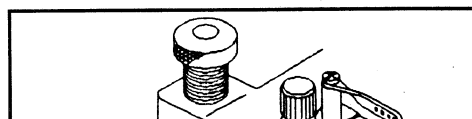

## 6-6 弯针连接杆的长度

1501-1504,两个连接杆之间的距离为100mm

1507-1508,两个连接杆之间的距离为87mm

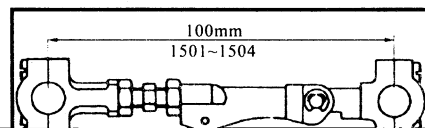



## 9-2 压脚的位置和提升量

压脚要正确的安装在压布杆上，并使针落在压脚的落针孔的中心。拧松定位螺钉A，一边确认针是否落在压脚的孔的中心，一边左右移动压脚进行调节。

### 9-2 POSITION OF THE PRESSER FOOT AND FOOT LIFT

Fit the presser foot properly onto the presser bar. Made sure the needle drops correctly to the center of the needle drop hole on the presser foot. Adjustment is made by loosening screw A.

#### ■ 压脚的提升量

离针板上表面7-10mm。

#### ■ FOOT LIFT

The presser foot should be 7~10mm above the top surface of the needle plate.

决定压脚提升杆限位器B的位置，使压脚提升杆不能下降过这个位置，然后用螺母C固定。

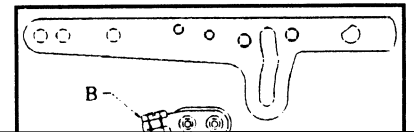
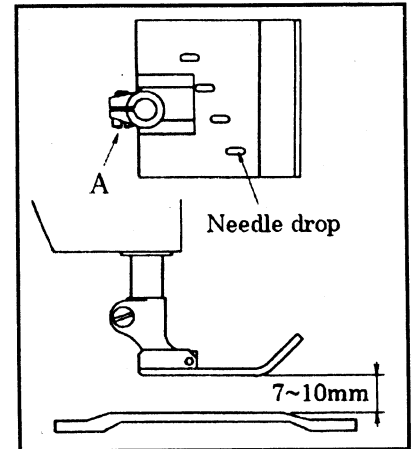

**【11】有关缝纫状态的调整 — ADJUSTING THE STITCH FORMATION**

**11-1 线的松紧度调整**

线的松紧度变化取决于布料、线和选择的线迹。机针线的松紧由螺母A调节。弯针线的松紧由螺母B调节。如果要拉紧,就顺时

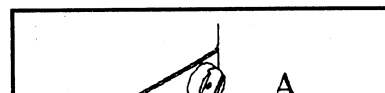



## 11-5 扇形过线器的调节

拧紧螺钉D,使下绷线E的位置离夹子台上面6~7mm。调节螺钉D,使弯针从最左的位置,向后移动,针尖通过弯针下面B线时,弯针线不要碰到扇形过线器F的最高位置A点,然后固定下来。

### 11-5 POSITION OF THE LOOPER THREAD TAKE-UP

Adjust thread guide E so that the clearance between thread guide E and the top surface of the guide plate is 6~7 mm. Adjustment is made by loosening screw D. When the

